

the-grabber

DO NOT ATTEMPT TO WELD AROUND MAGNETS. WELDING AROUND MAGNETS WILL NOT SUCCEED AND CAN BE UNSAFE.

Bolts of the correct size have been provided to mount the magnetic systems to the sides of the trough.

Use 'the-grabber' unit boxes as a marking template by placing them in the correct location for best retrieval.

Mark where the bolt holes should be drilled.

Be certain a 'the-grabber' box is placed on both sides of the trough exactly opposite each other with the bottom of the 'the-grabber' boxes 1/2" (more only if necessary for clearance) below the outside bottom of the trough.

Drill the bolt holes in the trough. Mount the boxes. No Utility connections required.

Caulk the seam between the trough and the 'Grabber' boxes if necessary. If you are going to caulk, we suggest silicone. Also, to get the caulking to adhere well you need to clean all surfaces absolutely clean. The best way to do this cleaning is by washing with alcohol.

INSTALLATION

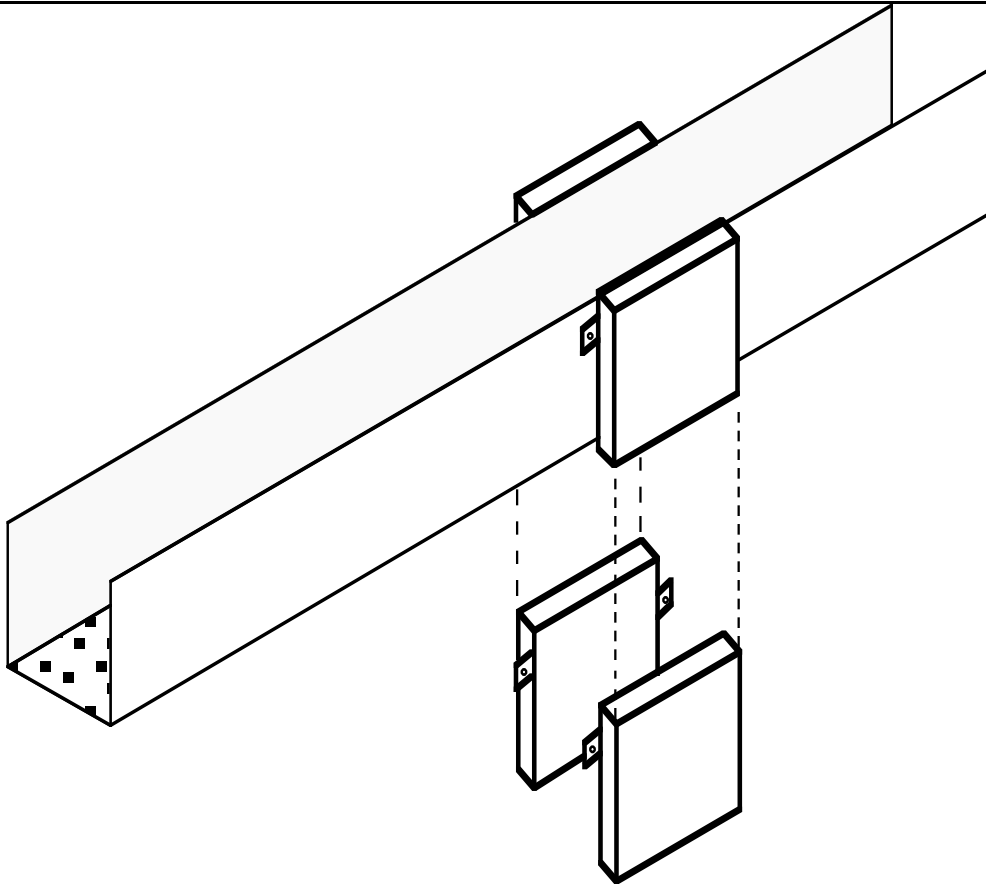

the grabber by MagZone Magnetics 9202 E Pioneer Dr Parker, CO 80138
Phone: 303-884-9030 email: hardenrj@earthlink.net